

TECHNICAL DETAILS

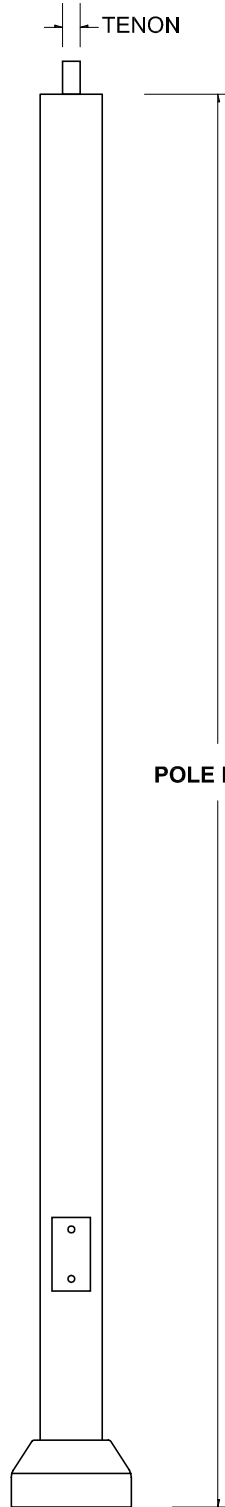

TENON



ELEVATION

POLE HEIGHT

POLE TOP FINISHING OPTIONS

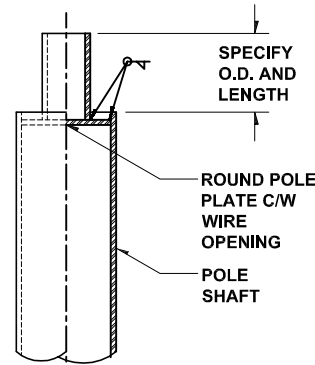

TENON DETAIL

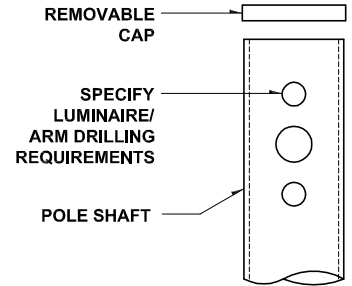

DRILLING DETAIL

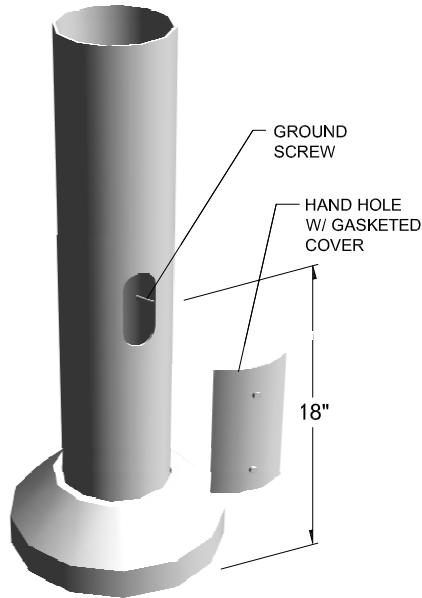

BASE DETAIL

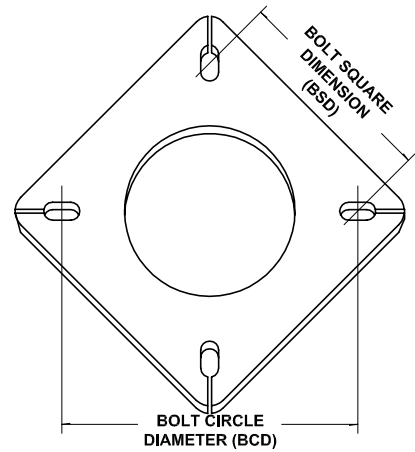

BASE PLATE DETAIL

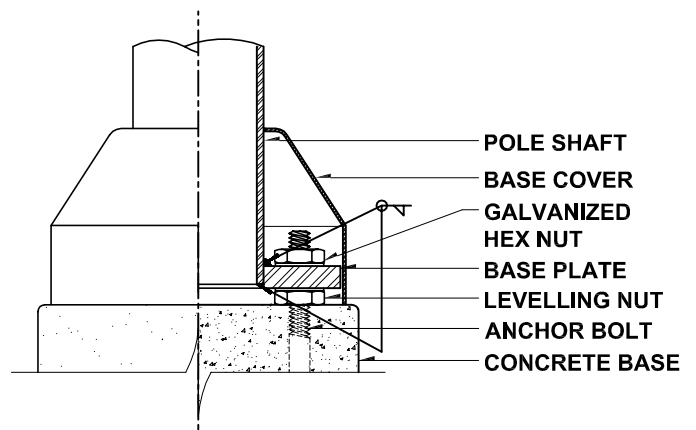

BASE PLATE WELD DETAIL



DYNAPOLE

www.dynapole.com

2425 Lucknow Drive, Mississauga ON L5S 1H1 Canada

Tel. (905) 671-1507 Fax (905) 671-4606 Toll-Free 1-877-DYNAPOLE

DRAWING TITLE:

STRAIGHT ROUND STEEL

MODEL:

SRS

DRAWN BY:

CGT

DATE:

06/28/04

SCALE:

NTS

NOTES: MATERIAL: STEEL
SHAFT: 50 000 PSI MIN. YIELD
BASE PLATE: 44 000 PSI MIN. YIELD