

## TECHNICAL DETAILS

### POLE TOP FINISHING OPTIONS

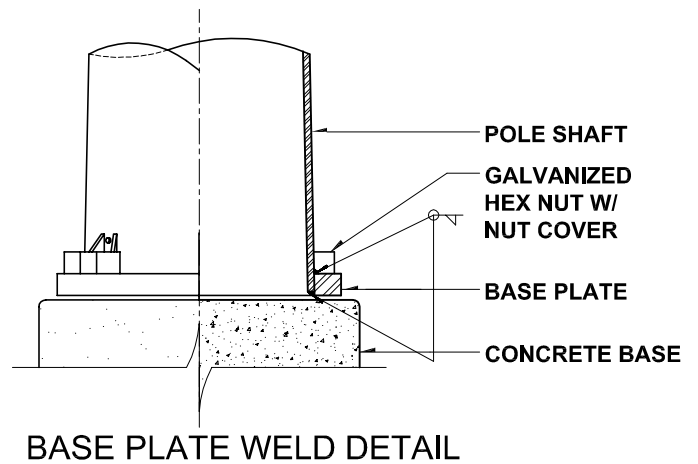
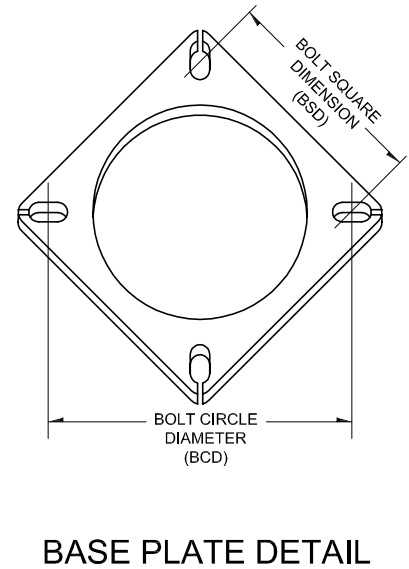
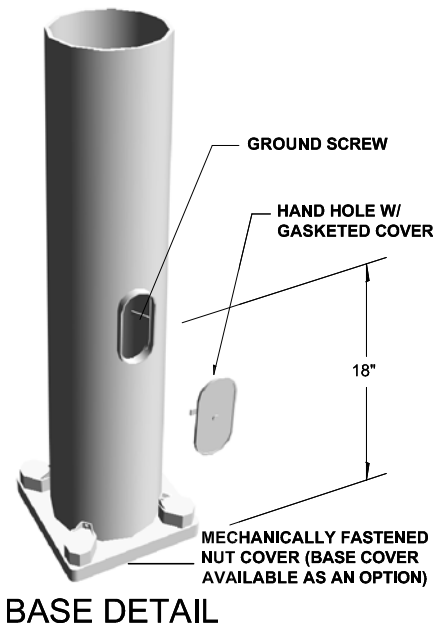
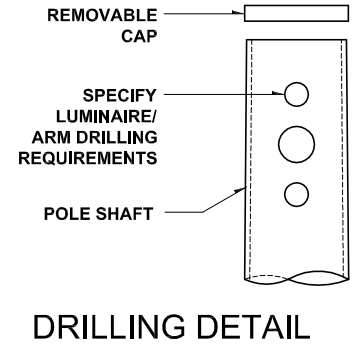
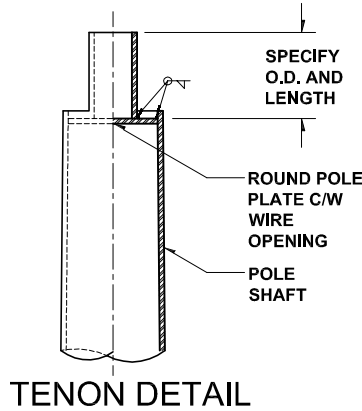
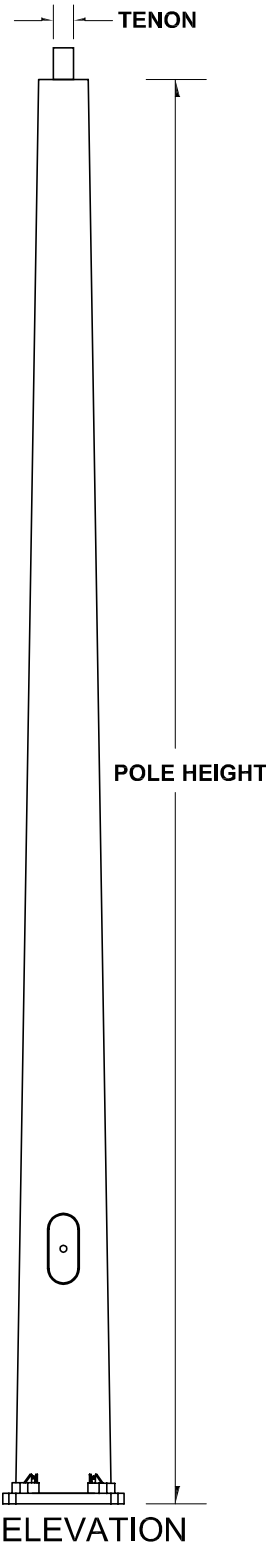
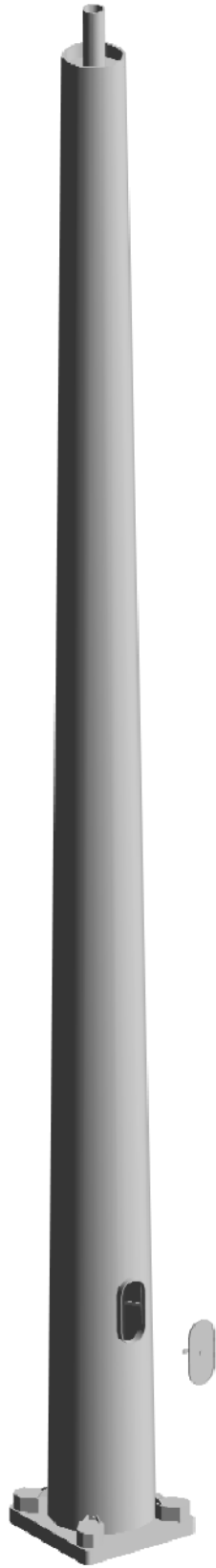

# DYNAPOLE

www.dynapole.com

2425 Lucknow Drive, Mississauga ON L5S 1H1 Canada

Tel. (905) 671-1507 Fax (905) 671-4606 Toll-Free 1-877-DYNAPOLE

DRAWING TITLE:

TAPERED ROUND STEEL

MODEL:

TRS

DRAWN BY:

CGT

DATE:

06/28/04

SCALE:

NTS

NOTES: MATERIAL: STEEL  
SHAFT: 50 000 PSI MIN. YIELD  
BASE PLATE: 44 000 PSI MIN. YIELD